

# Dinel<sup>®</sup>

Data Sheet

## **Thru-Wall Level Switch Model FLD-32**

*Distributed by*

**BRISTOL**  
 **INSTRUMENTS**

[www. BristolInstruments.com](http://www.BristolInstruments.com)

Bristol Instruments  
90 Canal Street, 4th Floor  
Boston, MA 02114

Toll free  
877-866-8500

- For limit level sensing of liquids in non-conductive tanks (through non-conductive wall of the vessels or pipelines)
- The sensor is designed with a high-frequency technology, enabling reliable function even in case of adhering conductive media
- Miniature performance in a flexible housing, optional installation on a slightly curving surfaces
- Attached using self-adhesive layer or special fastening bands
- Configuration and setup using the "programming" wire or magnetic pen
- LED status indication



**Thru-wall level switches FLD-32 "Flexi Watch"** are designed for indication of the presence of (conductive or non-conductive) liquids in glass or plastic vessels. The sensitivity and switching mode can simply be set up using the "programming" wire or magnetic pen, depending on the type of sensor used. The sensor housing is made of a flexible polyurethane material with a self-adhesive layer and holes for fastening bands.

### TECHNICAL SPECIFICATIONS

TECHNICAL SPECIFICATIONS		
Supply voltage		6 ... 30 V DC
Current consumption (idle-circuit condition)		max. 0.6 mA
Switched current (min. / max.)		3.3 / 40 mA
Voltage drop in the closed state		max. 6 V
Max. switching frequency		1 Hz
Ambient temperature range		-20 ... +70 °C
Diameter of the vessel for the attachment of the sensor		min. 300 mm
Maximum thickness of the vessel wall	conductive liquids	8 mm
	non-conductive liquids with $\epsilon_r < 10^*$	3 mm
Protection class		IP 67
Housing material		polyurethane
Type of connection cable		PUR 3 x 0.14 mm <sup>2</sup>
Weight (including 2m cable)		about 40 g
Weight (without cable)		10 g

\*)  $\epsilon_r$ , see relative permittivity table.

### RECOMMENDED RANGE OF APPLICATION

Detection of various types of liquids - water, diesel fuel, oil, cooling fluids, water solutions, certain types of solvents. Suitable for plastic container tanks, plastic tubs, pools, canisters, etc.

### UNSUITABLE RANGE OF APPLICATION

The sensor is not intended for measurement of levels on level gauges and on the walls of vessels with antistatic coating (partially conductive).

## DIMENSIONAL DRAWINGS

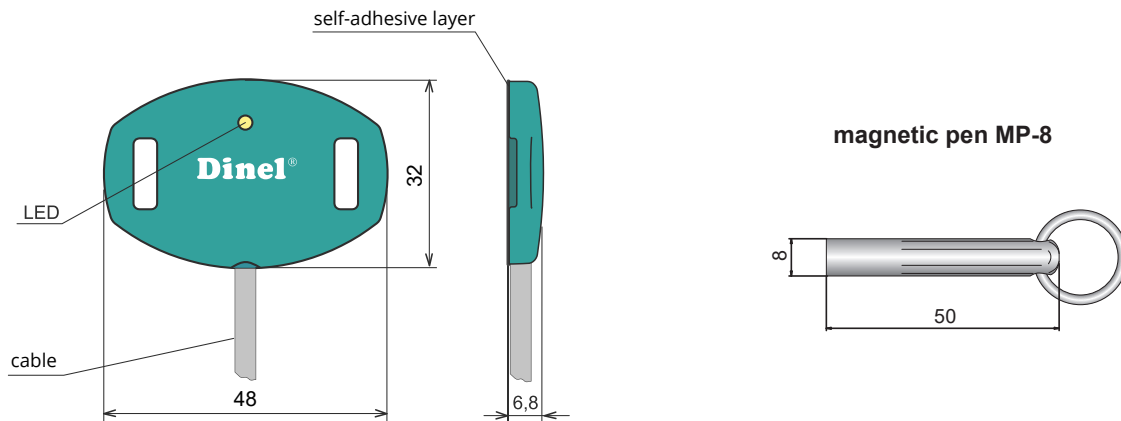

## SENSOR INSTALLATION

The sensor can be attached using self-adhesive layer or using special fastening bands. Individual sensors may be arranged next to each other without any effect on their function.

### FASTENING USING SELF-ADHESIVE LAYER

This technique may be used for flat or slightly curved surfaces with a diameter larger than 300 mm.

1. One protective film is removed from the adhesive layer and attached to the bottom of the sensor.
2. The target area should be cleaned and degreased.
3. Remove the second protective film and apply slight pressure to the sensor to attach it to the desired location.

When replacing or removing the sensor, the sensor should be detached from the wall of the tank carefully. If the original self-adhesive layer is destroyed, it needs to be removed from the sensor and a new one should be used (delivered as accessories).

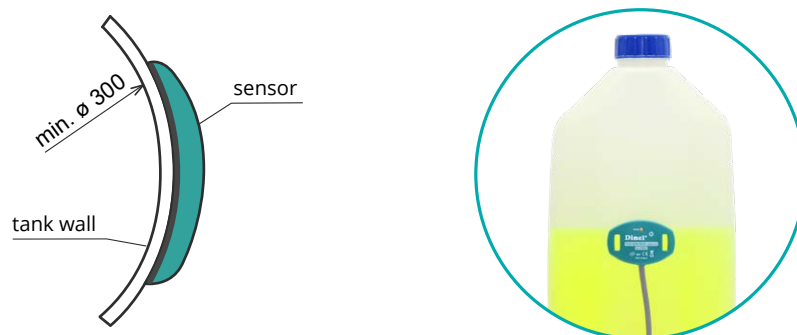

*Fastening the FLD-32 using self-adhesive layer*

### FASTENING USING ATTACHMENT BANDS

This technique is recommended for curved surfaces with a diameter of 180 - 300 mm. Use two bands for fastening (each has one end modified).

1. The modified end of the band is threaded from the inside through the fastening eyelet and glued over.
2. The same technique is used to attach the band at the second fastening eyelet.
3. The sensor is placed at the desired location on the tank, wrapping the bands around the tank, tightening them and gluing over.

The sensor must be fastened well otherwise the function of the sensor may be unstable.

**fastening bands**  
with  $\varnothing$  180 - 300 mm

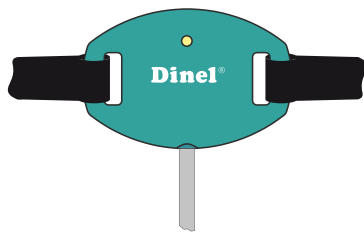

*Fastening FLD-32 using attachment bands*

## SENSOR SETUP

---

The setup is made by using the green wire (**so-called programming**) at version **FLD-32N-W-S** or by the **magnetic pen MP-8 at version FLD-32N-M-S** touching the sensitive spot on the body of the sensor. This can be used to setup the upper and lower limits of liquid level, SO modes (open contact when the level decreases) and SC (closed when the level decreases).

### Setup using programming wire at version FLD-32N-W-S

**SO mode: open when level decreases** - For empty or partially filled vessel (level below the lower edge of the sensor), the programming wire (P) is attached to the terminal 0V for about 2 seconds. Once the level reaches the upper edge of the sensor or when the tank is full, the wire (P) is attached to +U terminal for the same period (2 s).

**SC mode: closed when level decreases** - For empty or partially filled vessel (level below the lower edge of the sensor), the programming wire (P) is attached to +U terminal for approx. 2 seconds. Once the level reaches the upper edge of the sensor or when the tank is full, the wire (P) is attached to 0V terminal for the same period (2 s).

Note: The wire (P) is used only for programming the sensor. In all other situations it is unconnected.

For comfortable setup of the FLD-32N-W-S sensor, we recommend using wall-mounted evaluation unit Dinel, type SD-SU-1222-W with setup buttons, power supply, optical status indication and relay output.

### Setup using magnetic pen MP-8 at version FLD-32N-M-S

The setup is made by using the magnetic pen MP-8 touching on the sensitive spot (M) on the front side of the sensor. Short touch (for 2 s max.) of the magnetic pen on the spot (M) is used to open the sensor, longer touch of the magnetic pen (for 4 s min.) closes the sensor. This is used to set up the sensitivity to the measured medium and switching modes (SO, SC).

**SO mode: open when the level decreases** - For empty or partially filled vessel (level below the lower edge of the sensor), touch the magnetic pen on the sensitive spot for 2 s max. (M) (sensor opens). Once the tank is filled above the upper edge of the sensor, touch the magnetic pen on the sensitive spot for 4 s at least (M) (sensor closes).

**SC mode: closed when the level decreases** - For empty or partially filled vessel (level below the lower edge of the sensor), touch the magnetic pen on the sensitive spot for 4 s at least (M) (sensor closes). Once the tank is filled above the upper edge of the sensor, touch the magnetic pen on the sensitive spot for 2 s max. (M) (sensor opens).

## ELECTRICAL CONNECTION

The positive pole of the power supply (+U) is connected to the brown wire, the negative (0V) to the white wire. The output from the sensor is fitted with short-circuit protection. Capacitive loads and those with low idle-state resistance (light bulb) are evaluated by the sensor as a short-circuit.

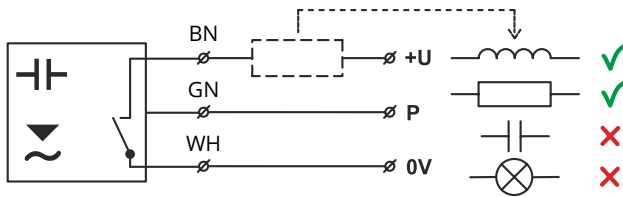

connecting the sensor with programming wire (version W)

Note: In case of strong environmental electromagnetic interference, routing of wires next to high-voltage lines or when the total distance is more than 30 m, the use of a shielded cable is recommended.

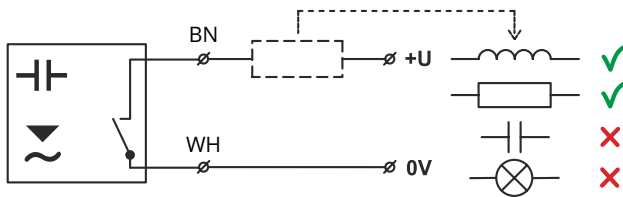

connecting the sensor without programming wire (version M)

### CABLE CORE IDENTIFICATION:

- BN** - brown
- GN** - green
- WH** - white

## STATUS INDICATION

control lamp	function
<b>orange LED</b>	<b>permanent shine</b> – the sensor is closed <b>dark</b> – the sensor is open <b>fast flashing (0.2 s interval) *</b> – setup error ** <b>slow flashing (0.8 s interval)</b> – short-circuit at the output of the sensor.

\* Sensor with "S" type of output, with each flash of LED, is closed for approx. 3 ms. This is a sufficiently short period to avoid unwanted contact making of the connected relay. For binary inputs, we recommend setting up the filtration so that pulses shorter than 3 ms are not detected.

\*\* Setting of the close (open) limits to the same level or erroneous resolution between the "close" and "open" levels (low medium permittivity).

## ORDER CODE

PRODUCT	
FLD-32	
PERFORMANCE	
N	non-explosive areas
SETUP TECHNIQUE	
M	magnetic pen
W	programming wire
TYPE OF OUTPUT	
S	electronic switch
CABLE	
K	cable length in m (2 or 5 m)
<b>FLD-32 N - W - S - K 2</b>	AVAILABLE PRODUCT ALTERNATIVES

## CORRECT SPECIFICATION EXAMPLES

---

FLD – 32N-M-S K 2

FLD – 32N-W-S K 5

## ACCESSORIES

---

### ***standard - included in the price of the sensor***

- 2x two-sided adhesive layer
- 1x magnetic pen MP-8 (in case of version that uses MP-8 setup)

### ***optional – for an extra charge***

- attachment band (1 packaging - 2x 0.5 m)
- two-sided adhesive layer

## PROTECTION, SAFETY, COMPATIBILITY

---

The sensor is fitted with the protection of supply voltage against polarity reversal, voltage peaks and current overload.

Shock protection is provided by safe supply voltage according to HD 60364-4-41.

Electromagnetic compatibility is provided by compliance with standards EN 55022/B, EN 61326-1, EN 61000-4-2, -4-3, -4-4 and -4-6.